



ProviewR  
OPEN SOURCE PROCESS CONTROL

# Release Notes V6.1

2025 01 28

Copyright © 2005-2023 SSAB EMEA AB

Permission is granted to copy, distribute and/or modify this document under the terms of the GNU Free Documentation License, Version 1.2 or any later version published by the Free Software Foundation; with no Invariant Sections, no Front-Cover Texts, and no Back-Cover Texts.

# Table of Contents

Upgrading to ProviewR V6.1.0.....	5
Updates.....	5
PROFINET.....	5
PROFINET Configurator.....	5
PROFINET Runtime.....	6
Ge.....	8
New dynamic properties.....	8
DigTransparency.SmoothTransition.....	8
Invisible.dim_level.....	9
Rounded rectangle, thin shadow.....	9
Undo, redo.....	9
Layout manager and script modules.....	9
Layers.....	11
Object graph defined with script.....	13
New Ge script functions.....	13
SetObjectVisibility().....	13
CreateLayer().....	13
GetWindowDimension().....	13
Layout().....	13
SetGraphOptions().....	13
TranslateObjectName().....	13
LayerSetActive().....	14
LayerResetActiveAll().....	14
MergeVisibleLayers().....	14
MergeAllLayers().....	14
MoveSelectToLayer().....	14
LayerGetFirstObject().....	14
LayerGetNextObject().....	14
New Xtt script function.....	14
TextDialog().....	14
Configurator.....	15
Command 'show objid/hex'.....	15
Class volume editor start.....	15
Class volume additional hierarchy.....	15
ClassDef flags Intern, Plc and Obsolete.....	15
Plc.....	16
Bus connections.....	16
SplitBus.....	16
JoinBus.....	16
GetBus.....	16
CStoBus.....	16
DataToBus.....	16
Status server communication changed to UDP.....	17
Kafka history server.....	18
Configuration.....	18
Configuration object.....	18
Kafka configuration file.....	18

Certificate.....	18
Selection file.....	18
DataQ.....	18
Classes.....	19
QCreateData.....	19
DataQ.....	19
QTrp, QTrpFF, QtrpRR.....	19
QOrder.....	19
QRemoteOrder, QTargetOrder.....	19
RemoteDataQ, TargetDataQ.....	19
TargetAttribute.....	21
Support for 64-bit ARM.....	22
Additions in V6.1.1.....	23
Subscriptions of arrays in Python API.....	23
Sev analyser graphics updated.....	23
Ge Transparency added to Bar, Trend and Axis objects.....	23
Ge Designer's Guide update.....	23
Additions in V6.1.4.....	24
Global configuration.....	24
geAspectRatioDelta.....	24
geAspectHeightDelta.....	24
Redundancy.....	24
Alarm blocking.....	24
Enumerations.....	24
Enumeration casting.....	24
Enumerations in Ge.....	25
Value fields.....	25
Axis.....	26
Enumeration signals and channels.....	26
String signals and channels.....	27
Plc function object StatusSeverity.....	27
Zigbee2mqtt interface beta version.....	27
Installation.....	27
Configuration.....	28
Script functions.....	32
Common script functions.....	32
file_search().....	32
terminate().....	32
Ge script functions.....	32
PushSelected().....	32
PopSelected().....	32
Wireshark QCom and RedCom dissectors.....	32
Upgrade procedure.....	32

# Upgrading to ProviewR V6.1.0

This document describes new functions in ProviewR V6.1.0, and how to upgrade a project from V6.0.0 to V6.1.0.

## Updates

### ***PROFINET***

The PROFINET configuration tool has gone through a major overhaul. As has the runtime implementation.

### **PROFINET Configurator**

The PROFINET configuration tool has been updated to better handle more recent versions of the GSDML specification. A few noteworthy changes:

- Updated GSDML conformance level.
- Configurator will never delete channels for you unless the Module Class changes. Instead it will notify the user that it couldn't populate a certain module/device and leave it to the user to remove them if the user want them generated by the configurator.
- The DAP is now populated as any other module is, as it's possible for a DAP to carry data.
- The generation of module and channel objects have been updated to name the signals in accordance to the GSDML data where possible using a best effort approach since we are still limited to how many characters we can use, and the GSDML is not.
- Runtime XML files have been updated to a slightly different schema. The upgrade procedure includes a step to convert these files. Most notable is that the tool now uses the ID to map modules/submodules to their respective slot/subslot instead of an index as was the case previously. The result is that it's now much more safe to switch between GSDML files for a device since the ID should (according to specifications) never change but the index order in which they appear can.
- It loads faster.
- Old runtime xml files are now deleted when the corresponding object is deleted, hopefully leaving you with a less bloated \$pwrp\_load folder.
- It now uses category menus for modules where implemented in the GSDML. Unfortunately, most vendors don't implement this neat feature.
- Input validation. It shouldn't be possible to input erroneous formatted data in the input fields anymore as all input is validated against either GSDML or other trivial specs like the format of an IP address or device name. In cases where the GSDML does not state anything the datatype is the limiting factor. Also, all input fields or selectable items now show some help about the item/field in question, hopefully making it easier for the user.

- SendClock/Reduction ratio is now populated according to GSDML and only falls back to defaults if not present in the GSDML. Previously only specification defaults were shown making it possible to choose a combination not supported by the device.
- You can now choose to skip the IP assignment leaving this to another controller or supervisor.
- Copying of slots should now be more robust and not crash on you in some situations.
- More diagnostics are saved in order to display accurate error messages in runtime.
- Phases are now implemented and can help reduce congestion during, for instance startup in large installations.

And a lot more minor fixes that should make it feel more mature.

## **PROFINET Runtime**

The runtime part of the PROFINET implementation has been updated. Alongside these changes the default graph for the PnDevice class was also updated.

The old dat files describing different vendors have been replaced by one single profinet\_devices.xml file which can be generated by the binary pn\_get\_deviceid should the need arise, do note that one would need access to the Profibus Foundation for their list of manufacturers. The Profinet Viewer use this file to display more helpful information about found devices.

## **Asynchronous Read/Write**

Asynchronous read/write are now in place. Previously you could do a write but without any means of getting the result back. Both Read and write are now implemented. They also have their own subgraph within the PnDevice graph as shown in Figure 1 and Figure 2. Each request can be programatically initiated by means of the SendReq attribute. The Status attribute (Ready/Busy) indicates wether we are ready for a transaction or not.

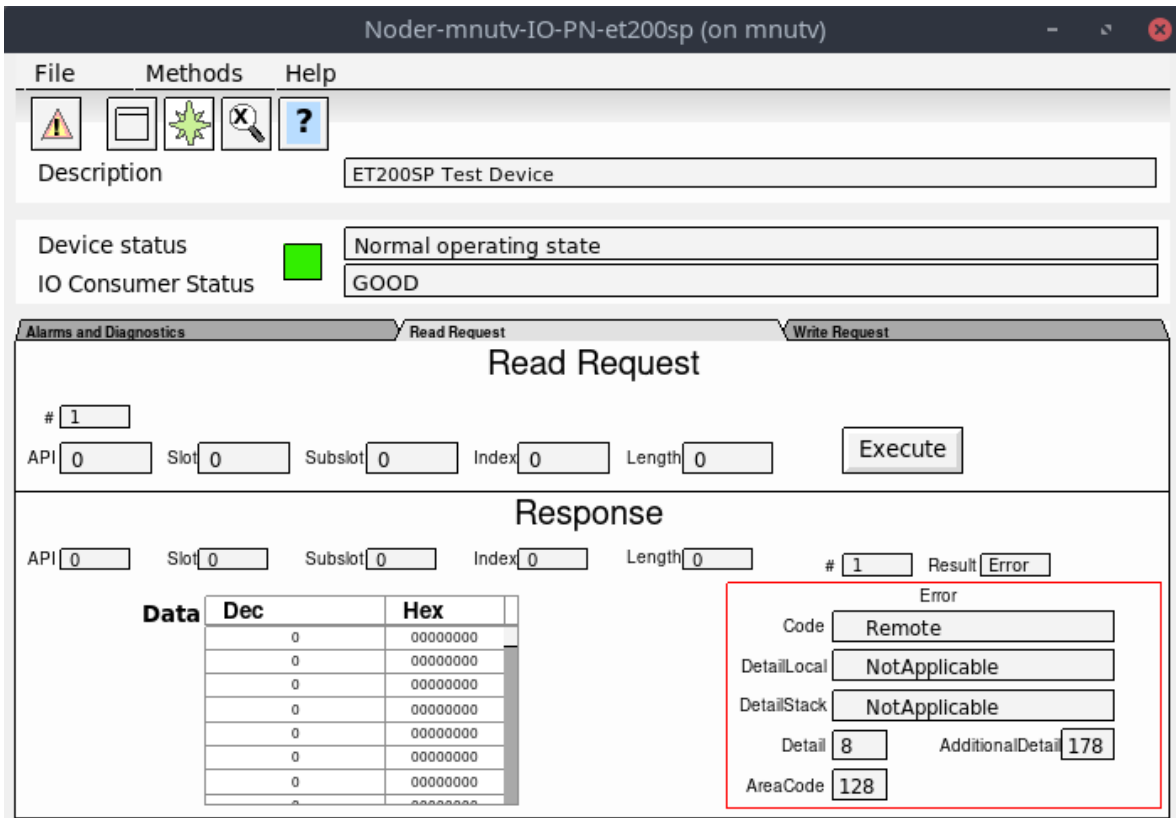

Figure 1: PnDevice Read Request after an erroneous read request

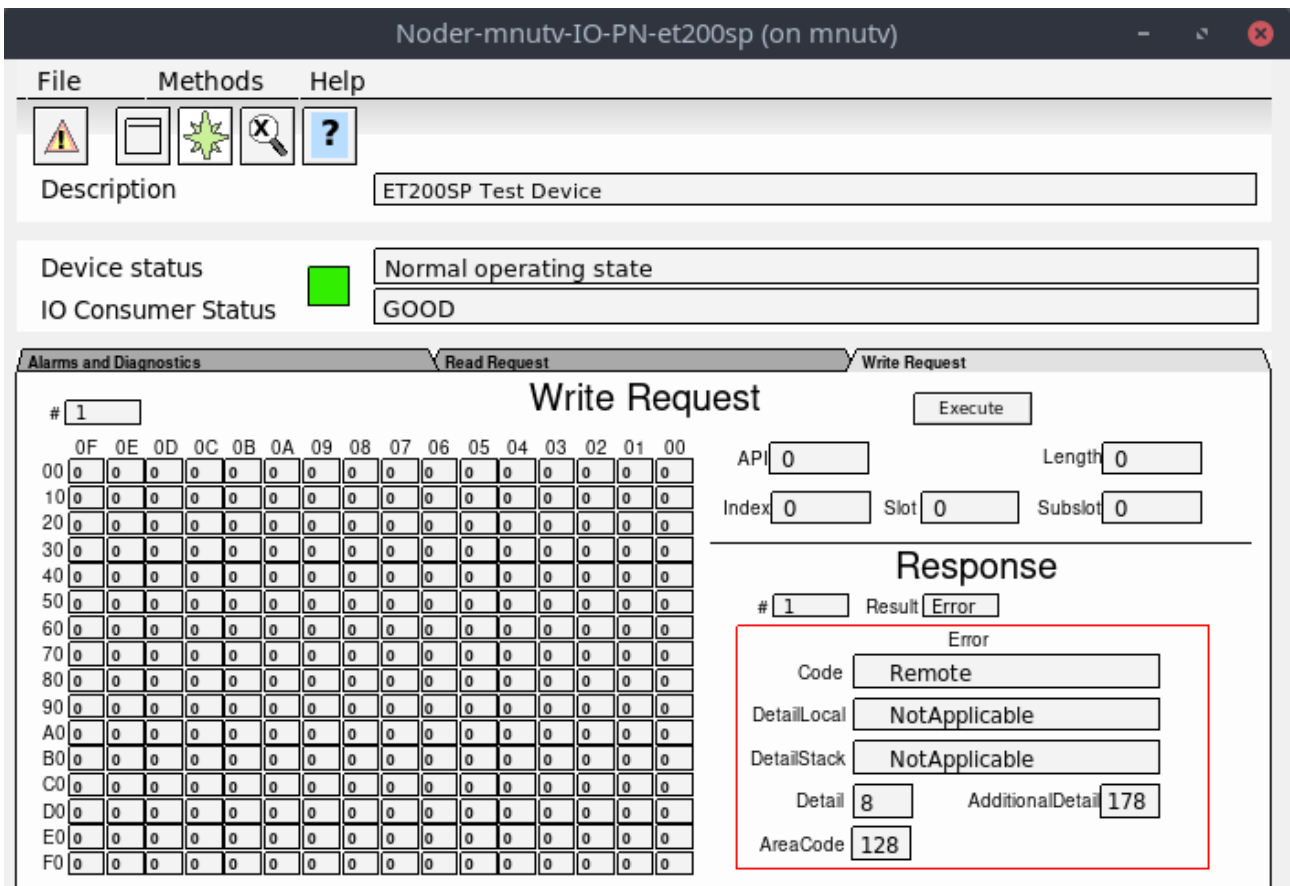
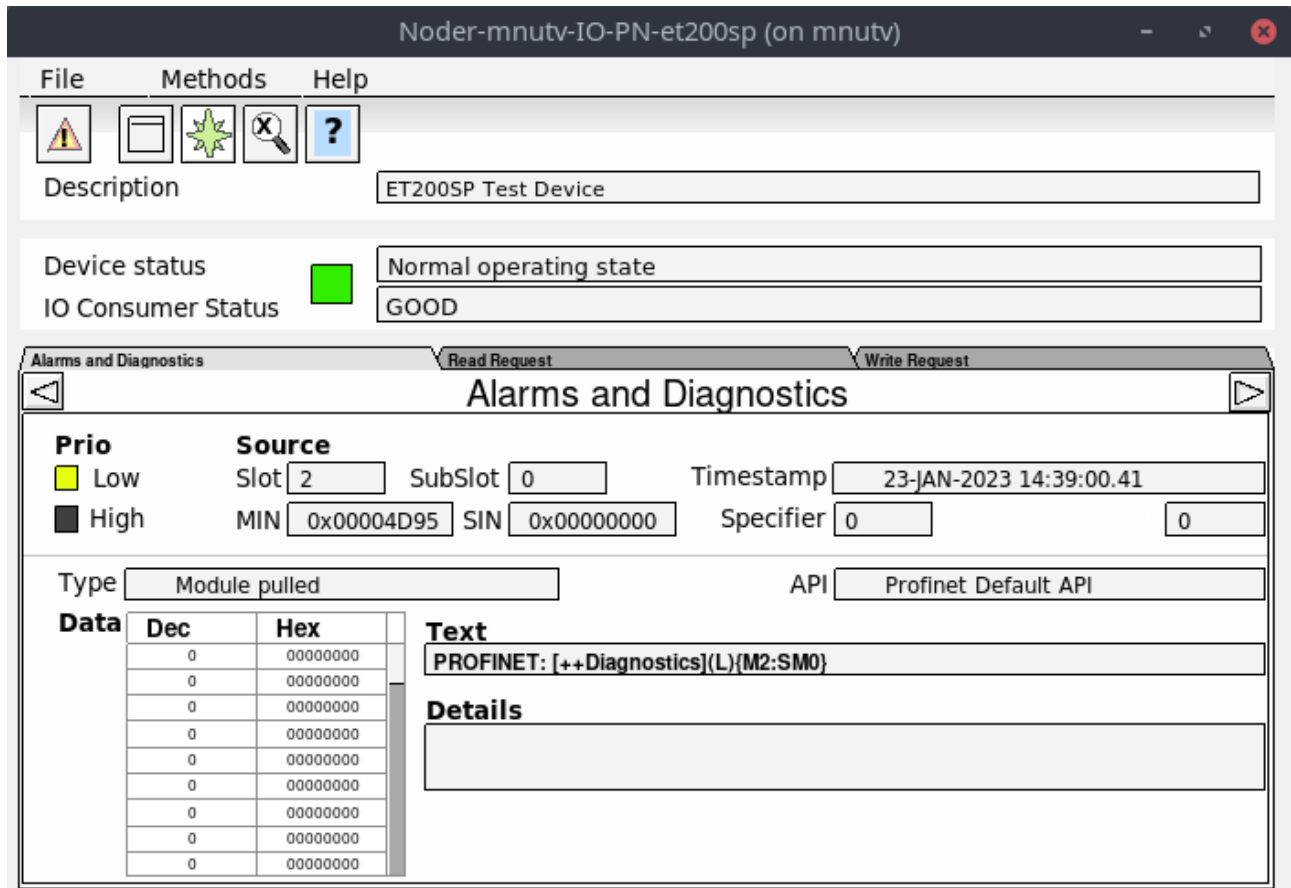

Figure 2: PnDevice Write Request after an erroneous write request

## Alarms and Diagnostics

Each PnDevice can now be configured to generate appropriate alarms depending on severity. You can also select to log these to the ProviewR log file, or both! Within each PnDevice there's a mask (AlarmActionSelect) that selects what action to take. And each module inherits (by default) that setting which, if needed, can be overridden on module level.



## \$pwrp\_cnf in runtime

This is more of a general update. The \$pwrp\_cnf environmental variable is now present in the runtime. This is now the default place where ProviewR runtime will look for GSDML files when no absolute path is given. Previously one had to place them in a folder which existed both in the development environment and in the runtime environment or in \$pwrp\_exe. Most often the files ended up in \$pwrp\_db, but having configuration files in \$pwrp\_db wasn't always the most elegant solution.

## Ge

### New dynamic properties

#### *DigTransparency.SmoothTransition*

DigTransparency.SmootTransition will cause a gradual transition of transparency over a number of scans.



### ***Invisible.dim\_level***

The previous action for Invisible.dimmed has been to draw black lines or texts with gray color. By setting Invisible.dim\_level to a value larger than zero, transparency will be used instead, and the dim\_level value specifies the transparency level.

### **Rounded rectangle, thin shadow**

Transparency has been disabled for rounded rectangles with shadow. If the new property thin\_shadow is set, transparency is enabled.

### **Undo, redo**

The journal is updated and handles several actions that previously was ignored.

### **Layout manager and script modules**

Script modules is a way of dividing the area of a graph into sections that will be positioned by a layout manager dependent of the dimension of the current window. Preferred size, nearest neighbors and a priority is set on each module. For windows with reduced size, modules with low priority will be dismissed. The graph has to be written as a script and call the Layout() function.

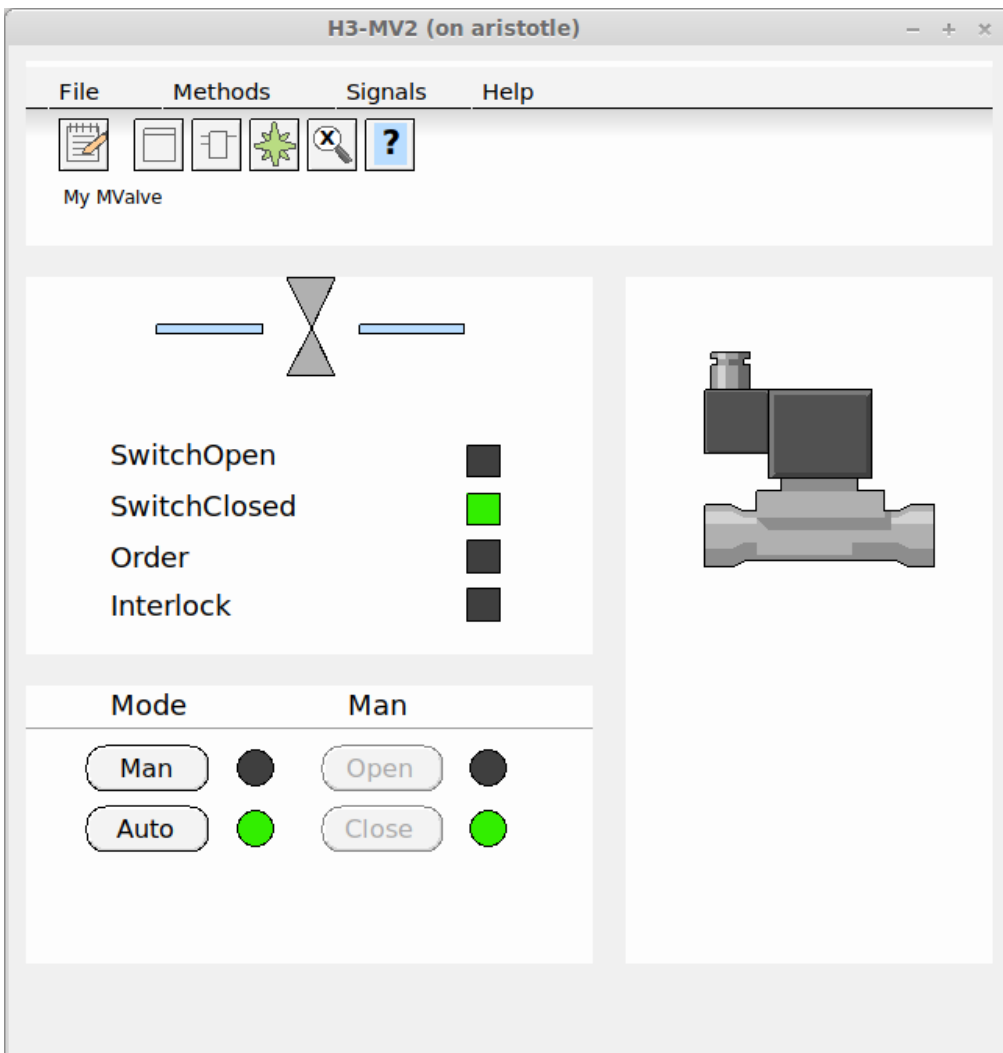

Fig Object graph, normal size

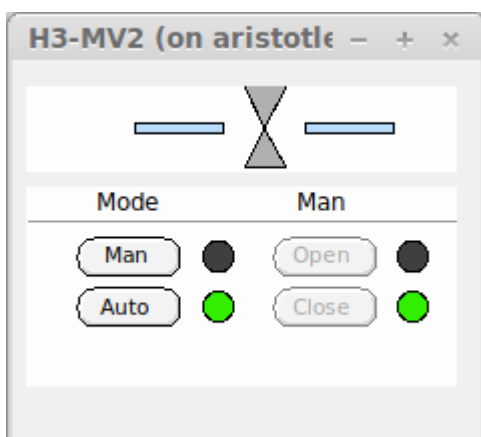

Fig Object graph, small size

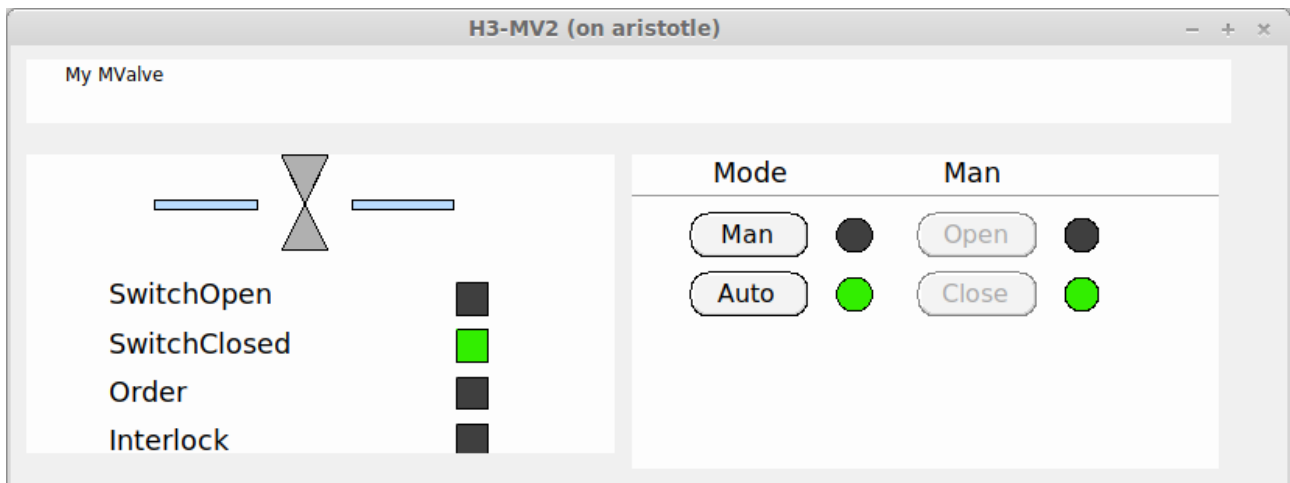

Fig Object graph, landscape format

## Layers

A layer is plane or level in the editor where you can create, edit and organize graphical objects. Layers are stacked on top of each others, and controls the visibility and and the possibility to edit objects.

When a layer is set active, objects in the layer can be created and edited. Only one layer can be active at a time, and there is no risk to accidentally move or edit objects in other layers. The activity is controlled from the lower window in the object tree view, the selected layer is set active. From this window, also the visibility of the layer is controlled. By clicking on the eye icon, the layer can be set visible or invisible.

In the upper window of the tree view, the organization of layers can be seen. Layer objects are position on the top level, and object in the layer are positioned under the layer object. By opening the layer object, dynamics for the whole layer can be set, eg transparency or color dynamics. The priority for color and transparency dynamics differs, and for colors, the dynamics for the individual objects have higher priority, wile for transparency, the dynamics for the layer has higher priority.

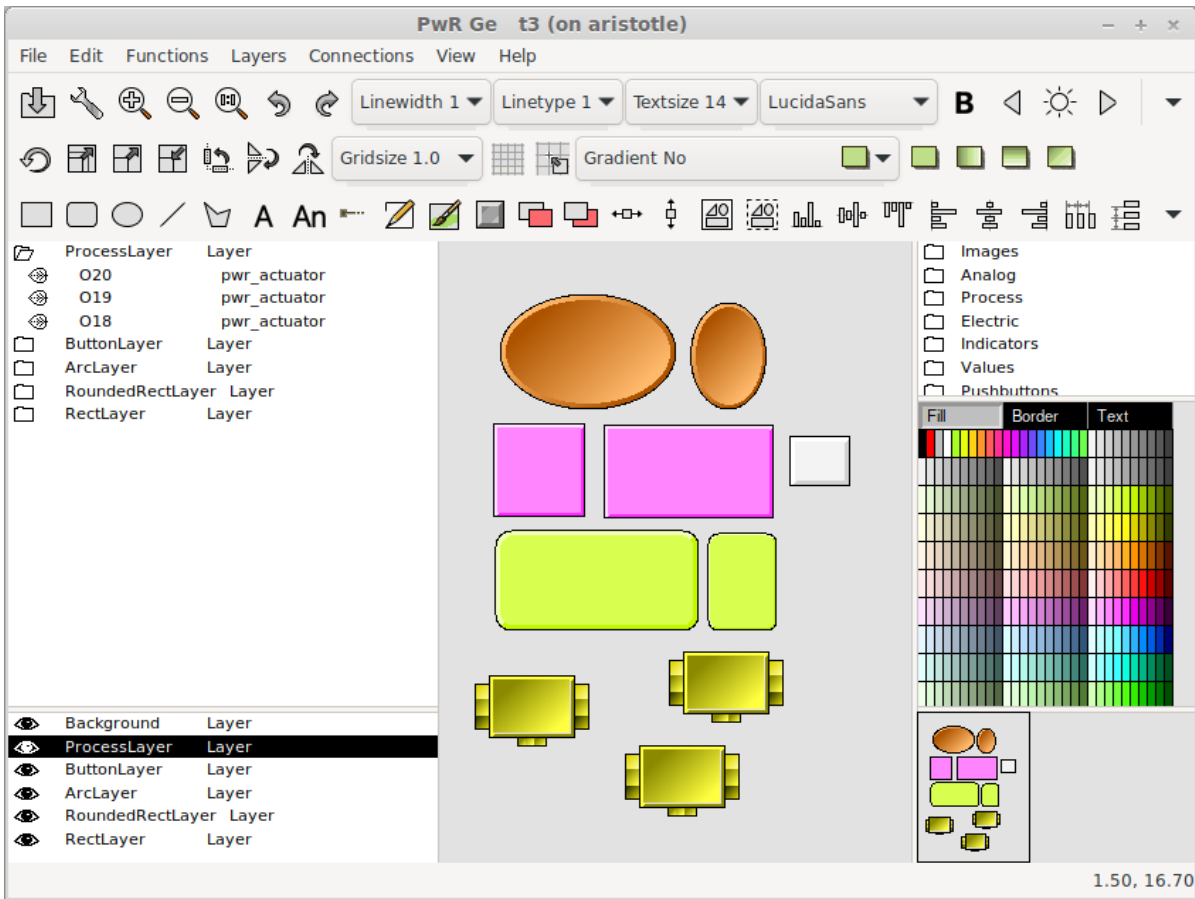

Fig Layers

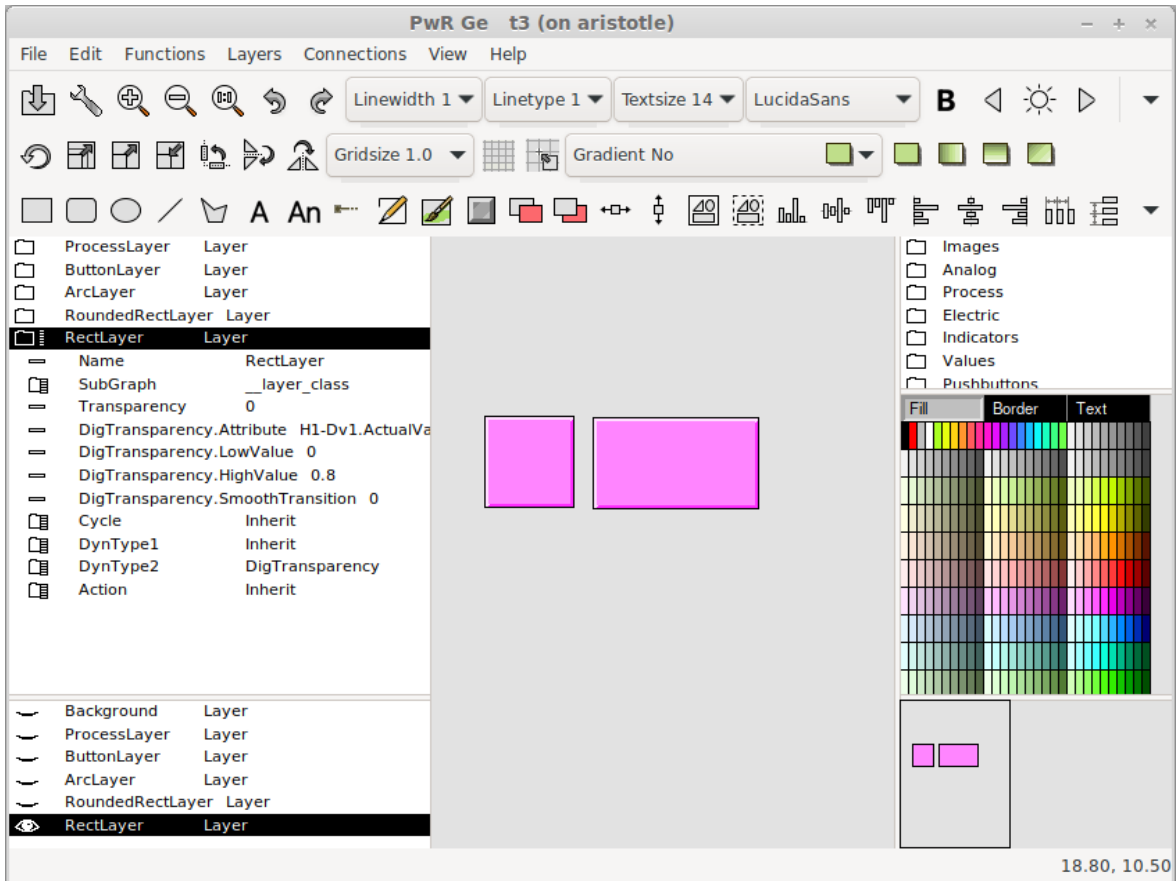

Fig Layer dynamic and visibility

From the Layers menu layers is created or deleted. It also contains functionality to move objects between layers and to merge layers can be found there.

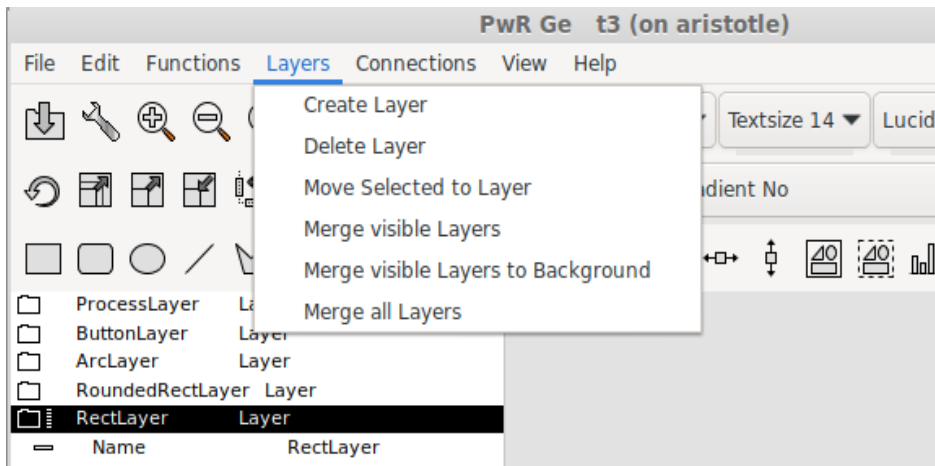

Fig Layers menu

## Object graph defined with script

If an object graph is defined with a Ge script, this has to be specified in the PopEditor attribute in the \$ClassDef object for the class. PopEditor should be set to *GeScript*.

## New Ge script functions

### ***SetObjectVisibility()***

Set object visibility to visible, invisible or dimmed.

### ***CreateLayer()***

Create a new layer.

### ***GetWindowDimension()***

Get the current dimension of the window containing the graph.

### ***Layout()***

Calculate a layout for the graph depending on the window dimension and the priorities and sizes of the script modules.

### ***SetGraphOptions()***

Set graph options.

### ***TranslateObjectName()***

Translate an object name containing symbols (eg \$object) to the real object name.

### ***LayerSetActive()***

Set a layer active.

### ***LayerResetActiveAll()***

Set all layers inactive.

### ***MergeVisibleLayers()***

Merge visible layers to one layer.

### ***MergeAllLayers()***

Merge all layers to background layer.

### ***MoveSelectToLayer()***

Move selected objects to the active layer.

### ***LayerGetFirstObject()***

Get the first object in a layer.

### ***LayerGetNextObject()***

Get the next object in a layer.

## **New Xtt script function**

### ***TextDialog()***

Display a dialog with a text and an icon.

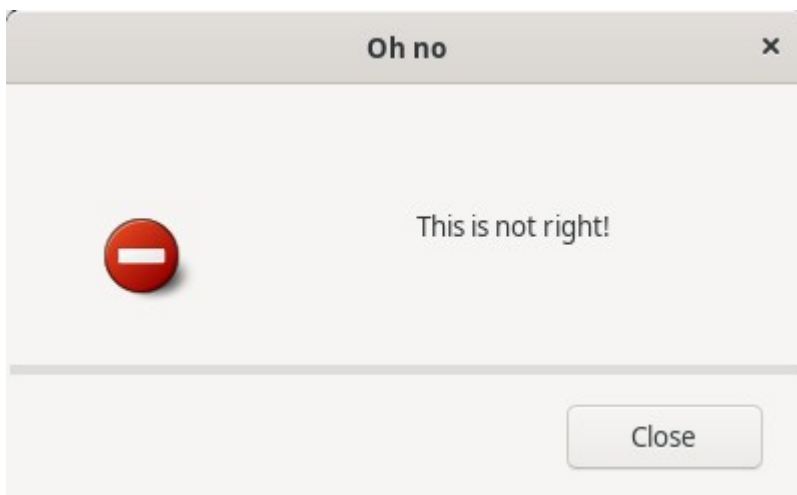

# Configurator

## Command 'show objid/hex'

/hexadecimal will show the object index in hexadecimal form which is convenient when examining flow files and object modules where the object index is part of the file name.

## Class volume editor start

The class volume editor can be started from the prompt with 'pwrs -c'. Now the file extension and directory can be omitted, eg

```
> pwrs -c cvolxxx
```

## Class volume additional hierarchy

One additional hierarchy level can be added between the Class object and ClassDef objects in class volumes. It's a suitable way to for example group classes belonging to a component or aggregate, or group classes describing a complex class with several internal classes.

The additional hierarchy object should be of class \$ClassHier.

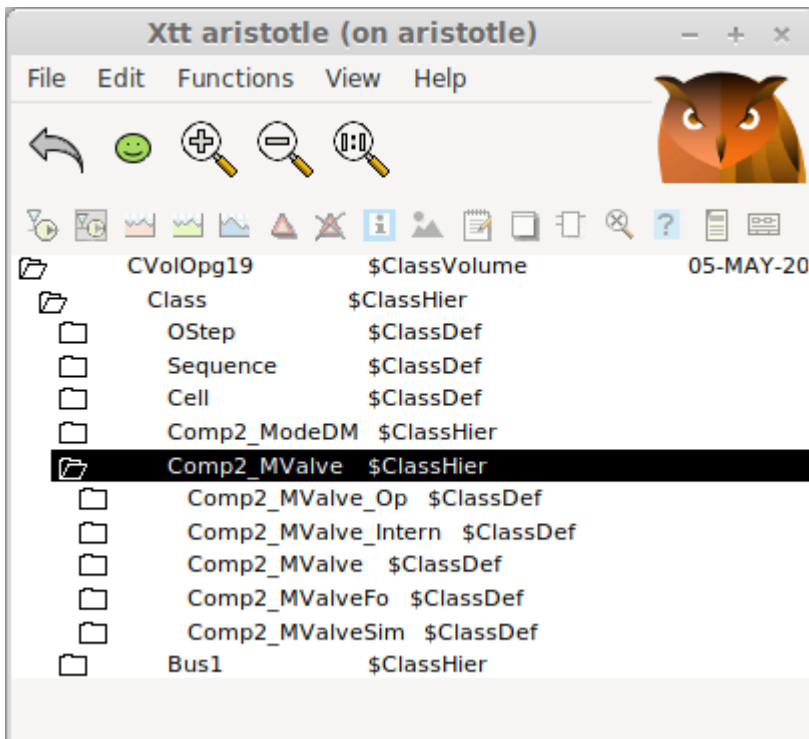

Fig Additional class hierarchy

## ClassDef flags Intern, Plc and Obsolete

Three new flags are added to the ClassDef Flags attribute

- Internal Bit for internal classes. When this bit is set, the class will not be displayed in the class volume palette.

- Plc Bit for Plc function objects. These classes will not be displayed in the configurator classvolume palette, only in the plc editor class palette.
- Obsolete. Bit for obsolete classes that will be removed in some later version.

## ***Plc***

### **Bus connections**

A bus connection is a convenient way to bundle related signals together in a single entity. It allows you to organize and manage multiple signals as a group. The data structure of the connection is described by a class defined in a class volume. A bus can contain other busses, making it possible to create complex data structures with hierarchical organization.

Beside the bus object a number of function objects can be defined to manage the bus.

#### ***SplitBus***

Function object to split the bus into it's attributes.

The object has one input for the bus and one output for each attribute in the bus.

#### ***JoinBus***

Function object to join a signal to a bus.

The object has one input for each attribute of the bus, and one output for the bus.

#### ***GetBus***

Function object to fetch a bus object or bus attribute.

#### ***CStoBus***

Function object to store a bus into a bus object or bus attribute.

#### ***DataToBus***

Function object that converts a DataRef to a bus.

The object has an input of type DataRef and an output for the [bus](#).



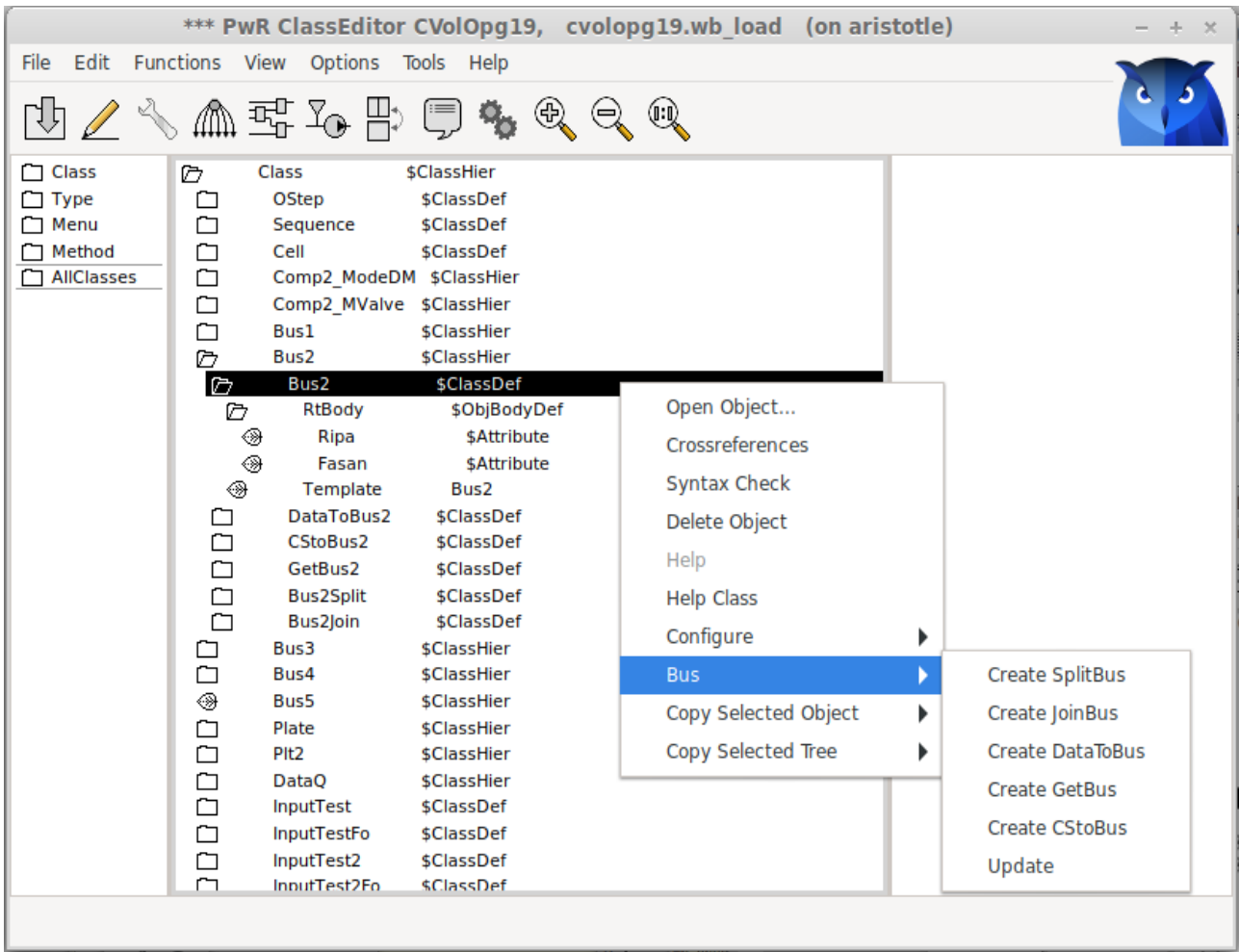

Fig Bus configuration menu

Below is an example of how the SplitBus and JoinBus object are used. The bus contains a sub bus that has its own split and join methods.

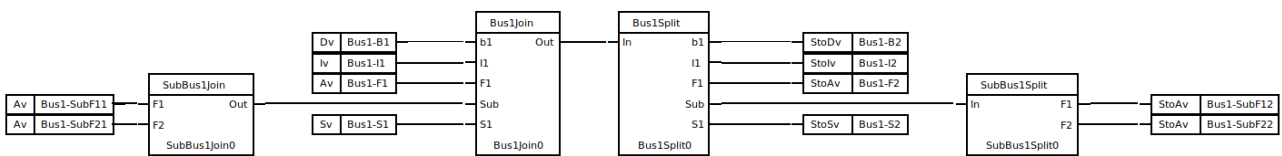

Fig Split and join bus

Inputs and outputs can be defined for any bus connection, and only pins with the same bus definition can be connected. To define an input or output for a specific bus, specify the bus in TypeRef.

## Status server communication changed to UDP

The status server previously used SOAP as communication protocol which caused a number of problems, mainly for the supervision center. This is now replaced by UDP. This means that the IP address now has to be part of the configuration for each node in the supervision center. It also means that the supervision center is not compatible with older versions. To maintain the compatibility with older versions of the supervision center, a version of the status server that still

uses SOAP is still available with the name `rt_statusrvv59`.

## ***Kafka history server***

The program `rs_export_rtdb` sends a selection of values from the real time database to a kafka server.

## **Configuration**

### ***Configuration object***

The program is configured with an object of class `Ssab_ExportRtdbServer` in the node hierarchy. The object is optional, making it possible to build `rs_export_rtdb` also for older releases.

### ***Kafka configuration file***

Kafka is configured with the file `$pwrp_load/kafka_config.ini`

```
[default]
bootstrap.servers=my.kafka.server.proview.se
ssl.ca.location=/pwrp/common/load/ca23.crt
security.protocol=SASL_SSL
sasl.mechanism=SCRAM-SHA-512
sasl.username=myuser
sasl.password=mypassword
enable.ssl.certificate.verification=True
message.max.bytes=15728640
acks=0
compression.codec=gzip

[consumer]
group.id=my_group
```

### ***Certificate***

If certificate verification is needed, a certificate file has to be present and the location for the file specified in the kafka configuration file.

### ***Selection file***

The selection file, `$pwrp_load/select.json`, contains names of the attributes that should be sent to the server. The file is generated by the program `rs_export_gen` that has to be executed before the server communication can be started. When changes are made in the database, also the selection file has to be updated.

## ***DataQ***

DataQ provides a way to store and transport data sets and make sure they are present in the right place at the right time. The coding is made in the plc editor making it possible to follow the data

flow through the system.

## **Classes**

### ***QCreateData***

Creates a dynamic object to store the incoming data. The dynamic object is inserted into the connected DataQ object.

### ***DataQ***

Container for dynamic (or static) objects. Together with the three types of transport objects it can implement different types of queues and stacks. The DataQ object has order outputs for the first and last object in the queue.

### ***QTrp, QTrpFF, QtrpRR***

These are transport objects that transport the data object from one DataQ to another. The transport can be done from rear to front, from front to front, from rear to rear, in forward or backward direction.

### ***QOrder***

QOrder objects are connected to the order output of the DataQ objects. The order output is a bus containing the order status, Data object reference and some status flags. Attributes of type Delayed, Limited, Condition, Pulse and Stored can be applied on the order.

### ***QRemoteOrder, QTargetOrder***

The QRemoteOrder and QTargetOrder pair makes it possible to transfer the order to remote nodes. The QRemoteOrder is connected to the order output of a DataQ object. When activated, the activity is transferred to the corresponding QTargetOrder in the remote node. The QTargetOrder will create a local dynamic object in the remote node which is supplied on the order output. The local data object can be a copy or a subset of the original data object, and the conversion is specified in the class volume with \$TargetAttributes. When the remote operation is performed, feedback data is transferred back to the original data object.

### ***RemoteDataQ, TargetDataQ***

RemoteDataQ/TargetDataQ is connected to a DataQ object and will handle a sub sequence of DataQ objects. The sub sequence can reside in a remote node. When data objects are entering the main DataQ, the TargetDataQ will also insert a corresponding data object into the sub sequence. During the operations in the sub sequence, feedback data can be sent back to the original data object. When the object reaches the end of the sub sequence, a feedback trigger is set to make it possible for the original data object to leave the main DataQ object.

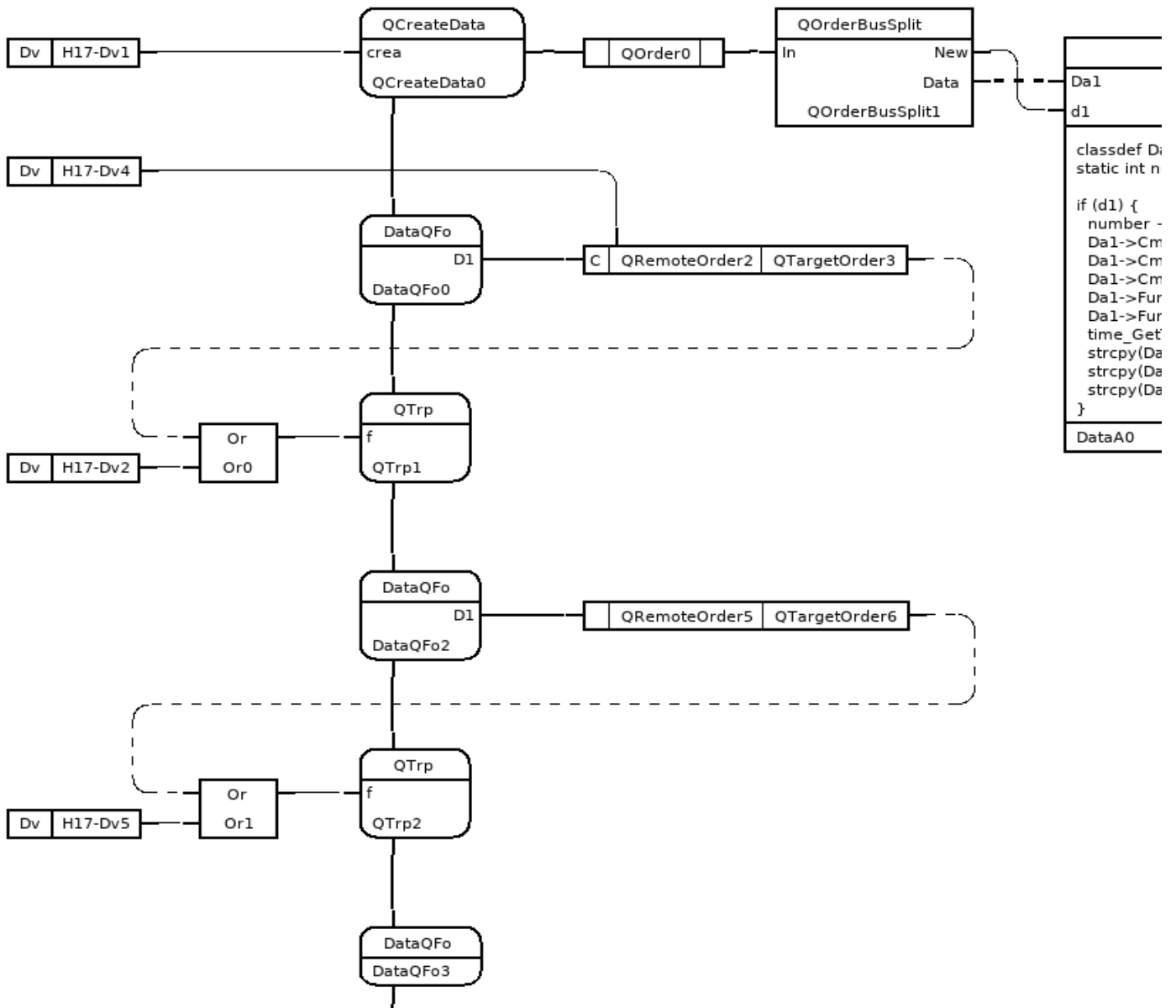

Fig DataQ with QRemoteOrder

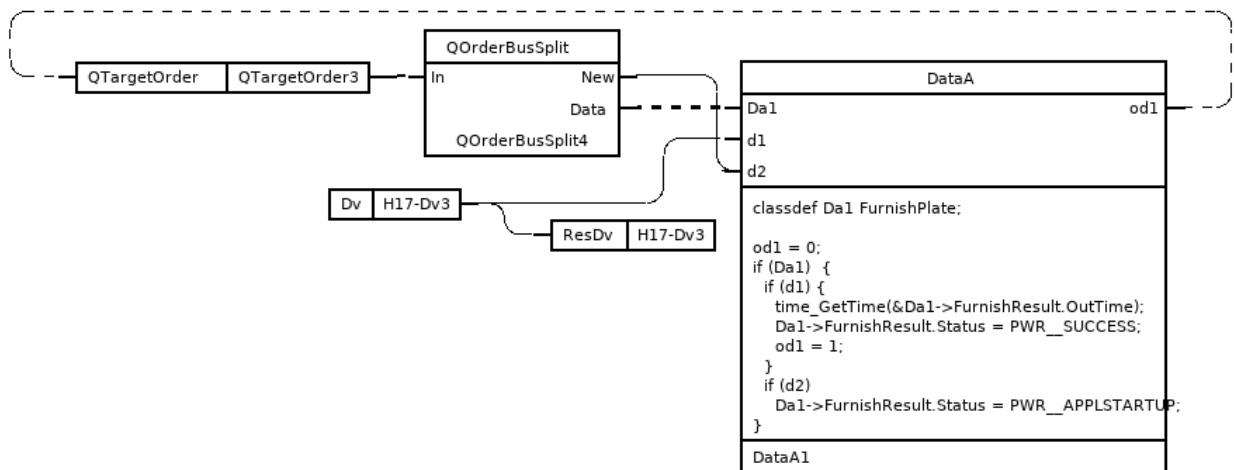

Fig QTargetOrder

## TargetAttribute

TargetAttribute is type of attribute that will be linked to a similar attribute in a source object.

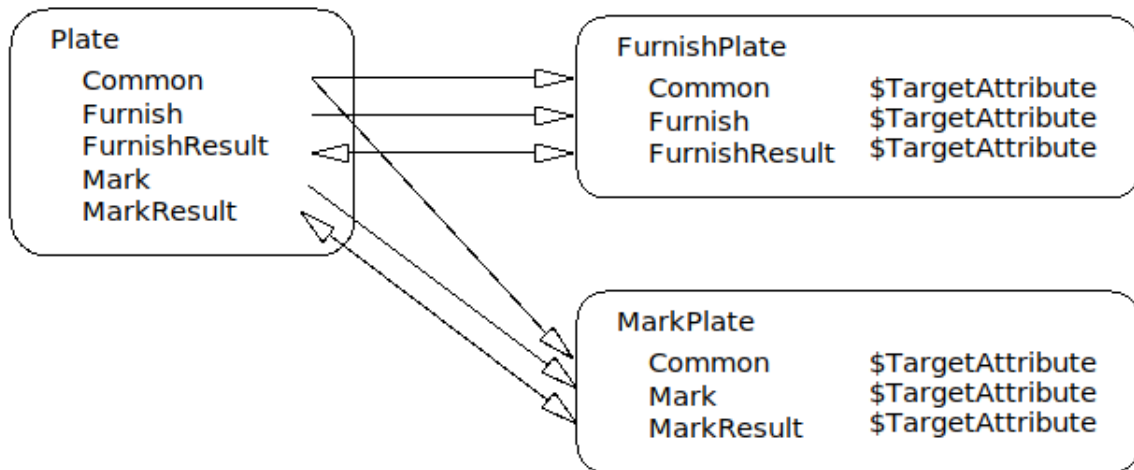

Fig Attribute dependency with TargetAttribute

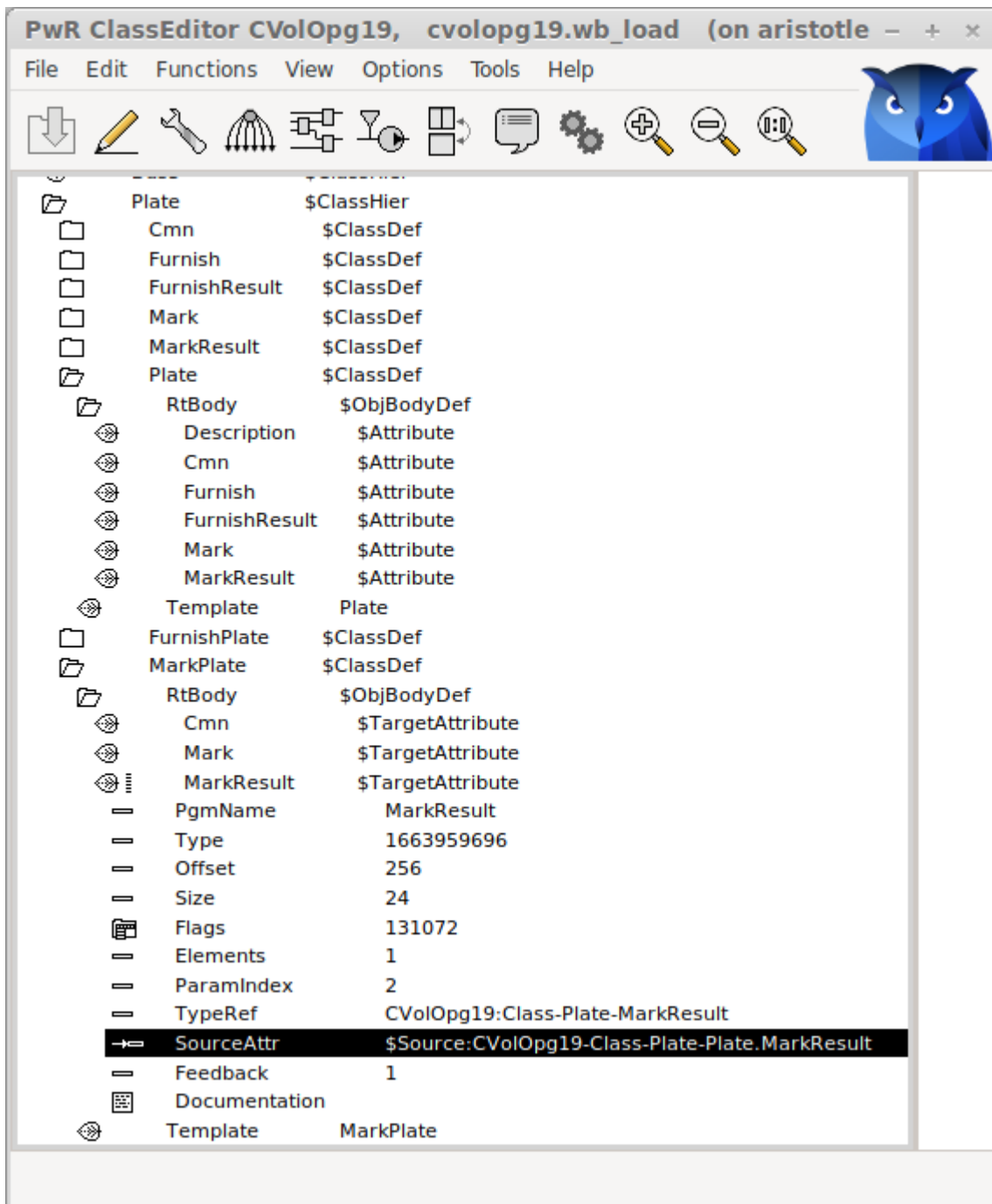

Fig \$TargetAttribute.SourceAttr

## ***Support for 64-bit ARM***

V6.1 can be built on 64-bit ARM.

# Additions in V6.1.1

## ***Subscriptions of arrays in Python API***

The runtime Python API pwrvt now supports reading, writing and subscribing of arrays. Arrays are implemented in the functions `Aref.value()`, `Aref.setValue()` and `Sub.value()`.

## ***Sev analyser graphics updated***

The graphics for the sev analyser is updated with color themes.

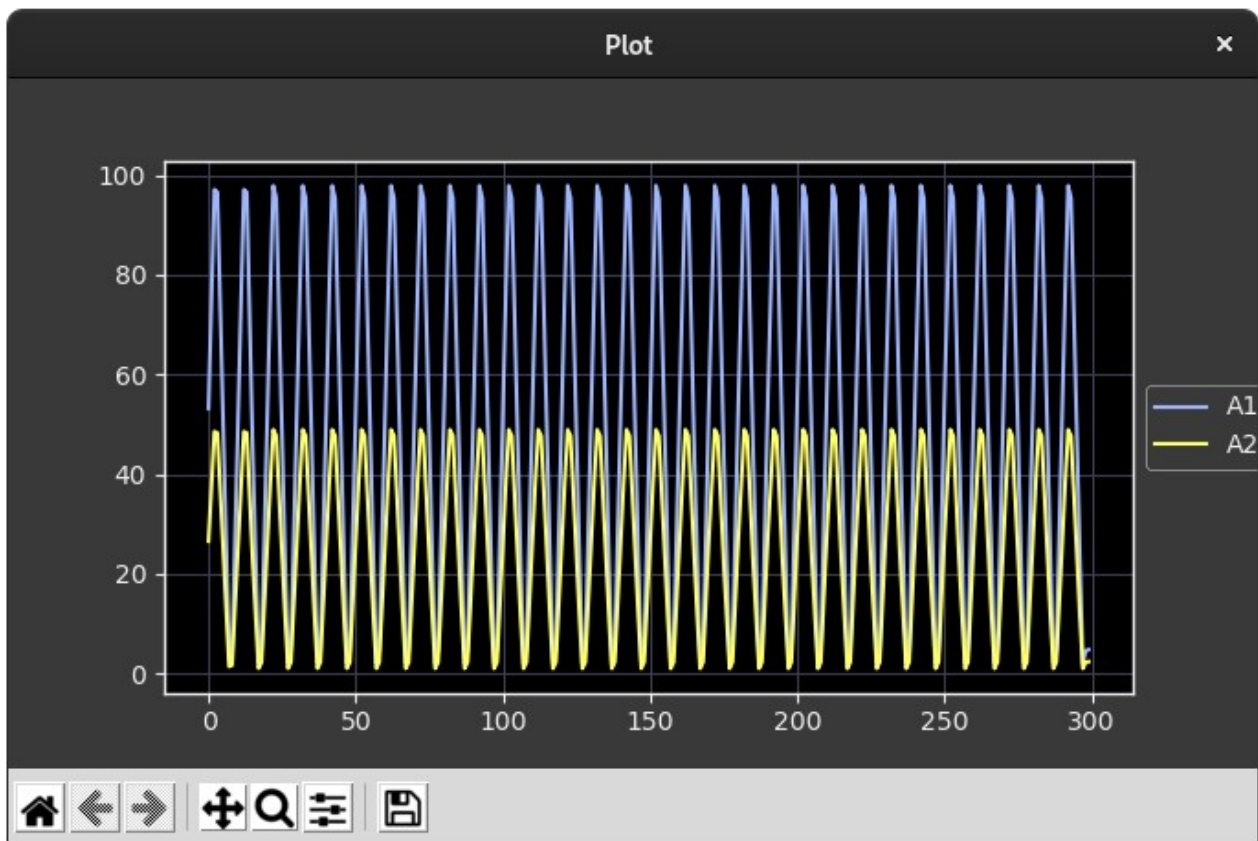

Fig Sev analyser curves

## ***Ge Transparency added to Bar, Trend and Axis objects***

Transparency dynamics was not previously implemented for Bar, Trend and Axis objects, but will now work also for these objects.

## ***Ge Designer's Guide update***

Ge Designer's Guide is updated with layers, color themes and more.

# Additions in V6.1.4

## ***Global configuration***

Two new variables that can be configured in /etc/proview.cnf

### ***geAspectRatioDelta***

Some desktops will produce strange behavior when min and max aspect ratio is set equal. geAspectRatioDelta will separate the min and max value for ge graphs.

#### **Example**

```
geAspectRatioDelta 0.02
```

### ***geAspectHeightDelta***

Some desktops in combination with old screens will calculate the ration between width and height erroneously for Ge graphs. With geAspectHeightDelta this can be partly corrected.

#### **Example**

```
geAspectHeightDelta 70
```

## ***Redundancy***

### **Alarm blocking**

Alarm blocking is included in the redundancy transfer protocol. Previously blocking was not supported for redundant nodes, and blockings where not transferred and displayed correctly in the block list and navigator. Now the blocking events are included in the event monitor transfer and the block list and blocking display in the navigator will be correct after a switch.

## ***Enumerations***

### **Enumeration casting**

The Enum type in ProviewR makes it possible to associate a set or texts to an enumeration value by creating a specific enumeration type from the Enum type. To display the text for the current enumeration value for an attribute, the attribute has to be defined with the specific enum type. Now it's possible to create generic enumeration attributes that can display different specific types in different instances. This is done by a casting mechanism, where the enum attribute is preceded by a cast attribute that contains the type id for the specific type. One example is the new Ev (Enumeration value) object, that contains a cast attribute CastActualValue of type CastId, followed by the ActualValue attribute of type Enum (or actually pointer to Enum). In one Ev object CastActualValue can be set to pwrb:Type-OnOffEnum and show the text On or Off. In another Ev object CastActualValue can be set to pwrb:Type-EventPrioEnum and show the texts A, B, C or D.



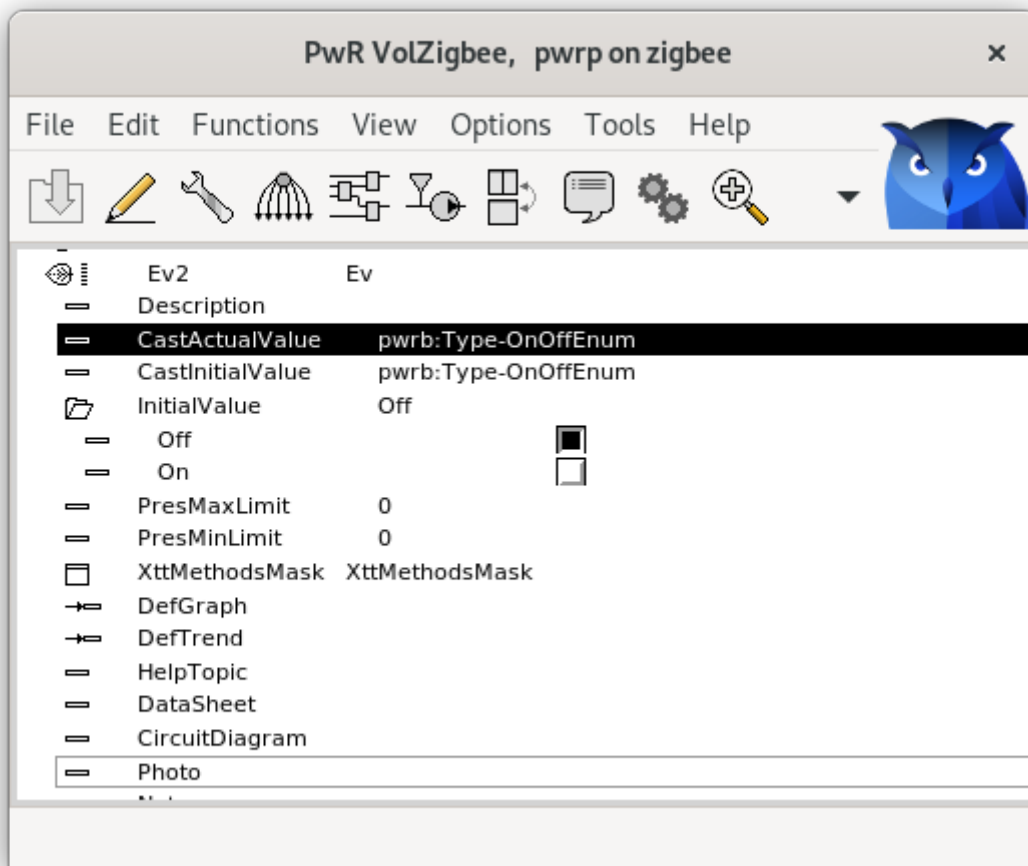
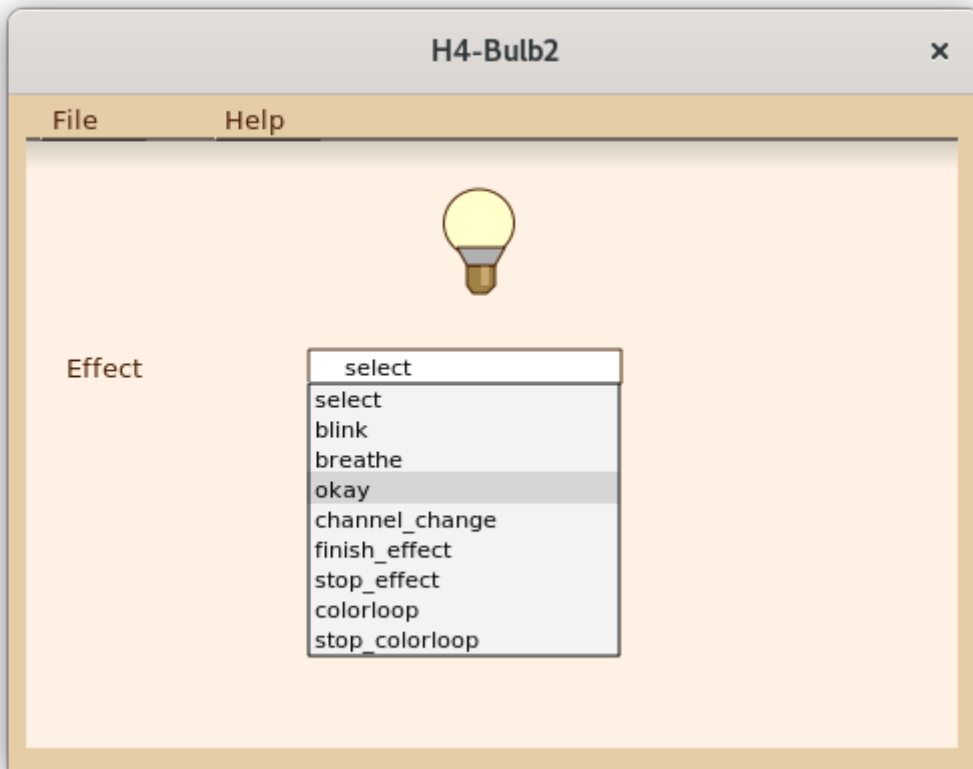

**Fig Ev casted to OnOffEnum type**

## Enumerations in Ge

### *Value fields*

To display the text for an enumeration value in a Ge value field, the format for a ##Enum type is set to "%s". This was implemented already in previous versions but now it also works in the web interface. A new feature is that an InputValue field act as an option menu and displays a list of the enumeration texts when the field is activated. This is not implemented in the web interface yet.



**Fig Activated value input field for an enumeration**

### **Axis**

An Axis object can display enumeration texts when type is set to `##Enum` and format `"%s"`.

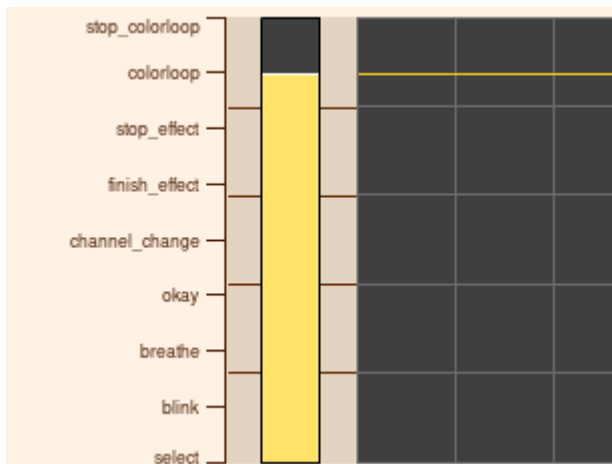

**Fig Axis with enumeration texts**

### **Enumeration signals and channels**

The new enumeration signals are

- Ev, enumeration value.
- Ei, enumeration input.
- Eo, enumeration output.

All three contains a generic enumeration attribute, ActualValue, that can be casted to a specific enum type. Also InitialValue can be casted to to display the initial value as a text.

To Ei and Eo there are corresponding channel classes, ChanEi and ChanEo. There are also a set of function objects to handle the signals in the plc code, GetEv, GetEi, GetEo, StoEv, StoEi, StoEo, CStoEv, CStoEi and CStoEo. The internal format for an Enum is Int32 and the function objects can be connected to integer input and outputs.

The signals are IO copied, and the actual values are stored in area objects in the system volume.

## ***String signals and channels***

The new string signals are Si, string input, and So, string output. The corresponding channel classes are ChanSi and ChanSo. There are also a set of function objects to handle the signals in the plc code, GetSi, GetSo, StoSi, StoSo, CStoSi and CStoSo.

The signals are IO copied, and the actual values are stored in area objects in the system volume.

## ***Plc function object StatusSeverity***

Evaluates the severity for an attribute of type pwr\_tStatus. The object has 5 digital outputs for severity fatal, error, warning, success and zero.

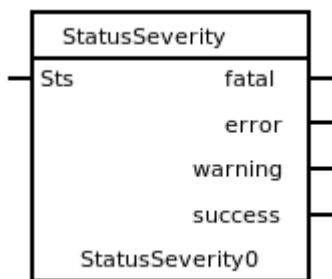

## ***Zigbee2mqtt interface beta version***

Zigbee2mqtt is an interface to over 3000 home automation devices from vendors as Philips, IKEA, Lidl. Device objects in ProviewR are generated from the device data in Zigbee2mqtt.

### **Installation**

To run Zigbee2mqtt you need a zigbee USB dongle. See [www.zigbee2mqtt.io](http://www.zigbee2mqtt.io) which USB dongles are supported and also how to install zigbee2mqtt. ProviewR is communicating with the Zigbee devices through an mqtt server. ProviewR can be run on the same node as the mqtt server or on another node.

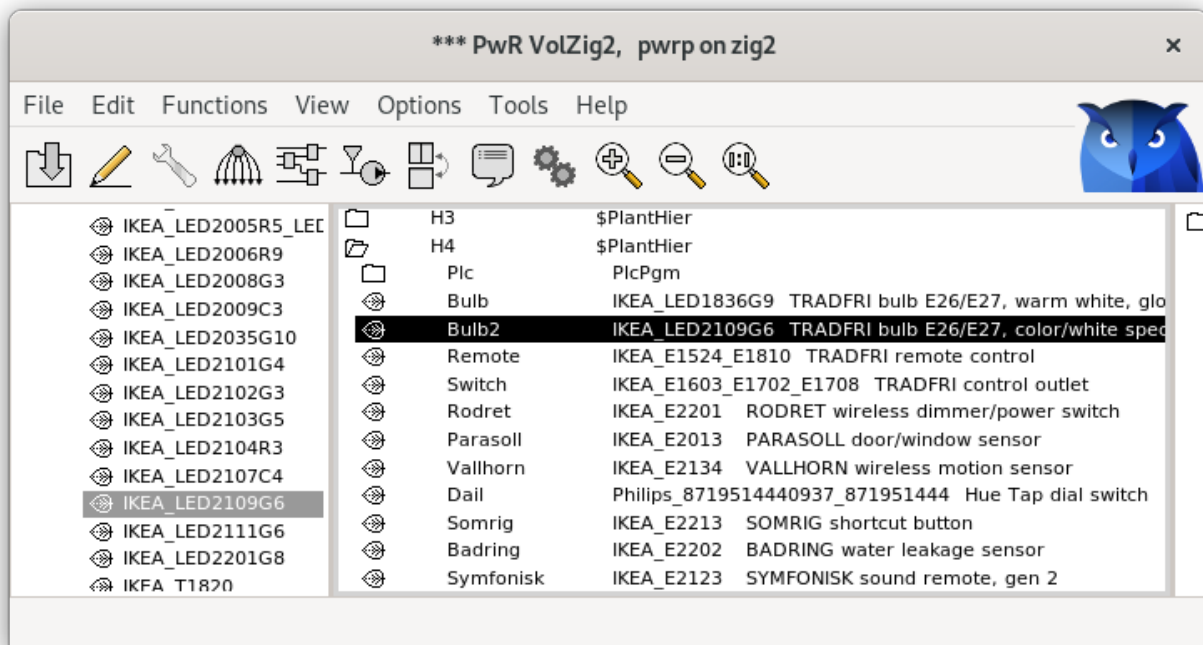

**Fig Raspberry Pi with Sonoff Zigbee USB dongle**

## **Configuration**

In ProviewR a Zigbee device is configured with three objects, a main object in the plant hierarchy, an IO object in the node hierarchy and a function object in the plc program. The function object is missing for some devices.

The main object is fetched from Plant/Components/Zigbee2mqtt in the configurator palette and placed somewhere in the plant hierarchy.



### Fig Configuration of zigbee main object

The connection to the MQTT server is configured with a Zigbee2MQTT\_Client object under the IO object in the node hierarchy. If the MQTT server is running in a remote node the host name or IP address for this node is configured in this object. Also username and password for access to the server is configured if this is required. Below the Zigbee2MQTT object IO objects for the devices are configured. They are fetched from Node/IO/Zigbee2mqtt/Devices in the palette and should be connected to the main object with the IoConnect method.

Each device has to be paired with the Zigbee server, and after the pairing sequence, the identity of the device will be displayed in the zigbee2mqtt log. This id, a 16 digit hexadecimal number prefixed with 0x, should be inserted into the DeviceID attribute of the IO object.

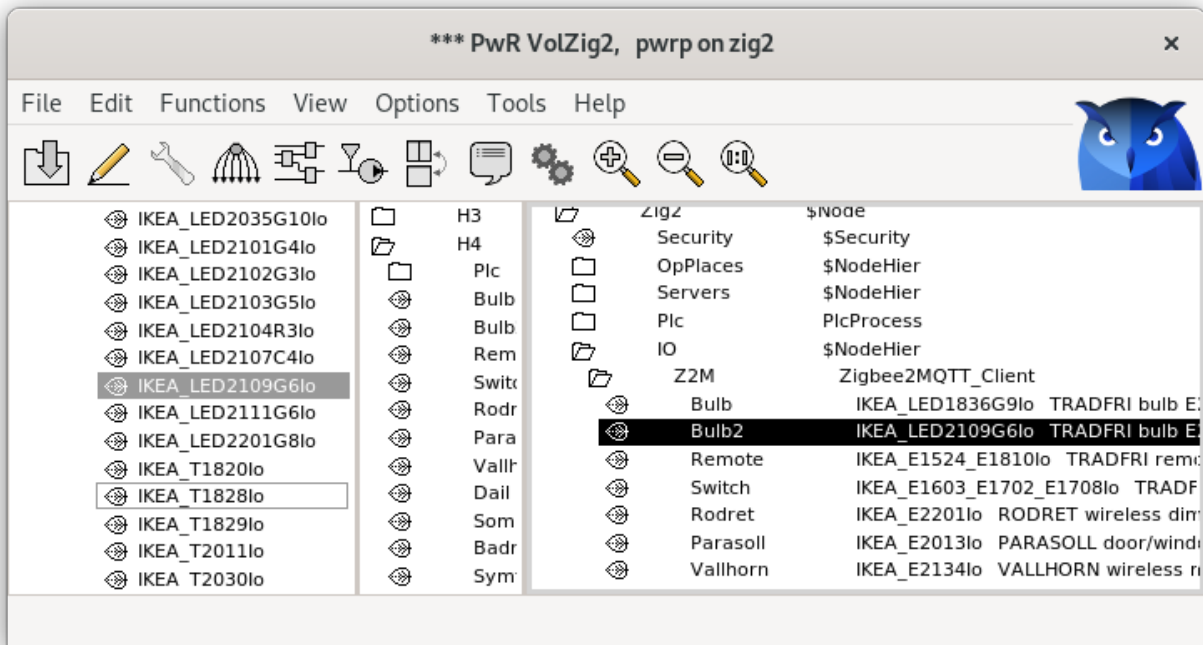

**Fig Configuration of IO objects in the node hierarchy**

In the plc editor, the function objects are found under Components/Zigbee2mqtt in the palette. The function object should also be connected to the main object.

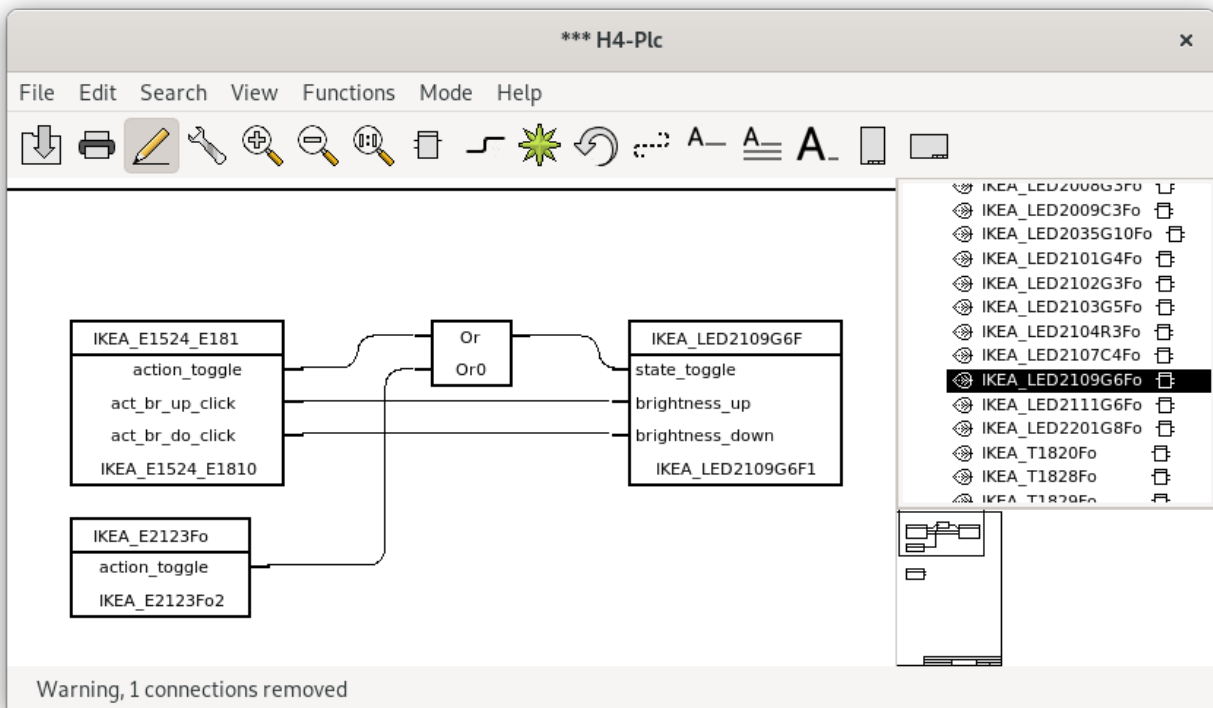

**Fig Plc function objects**

In runtime each device has an object graph. In the example below for the IKEA color bulb, the bulb can be switched on or off and brightness, color temp and color can be set with sliders.

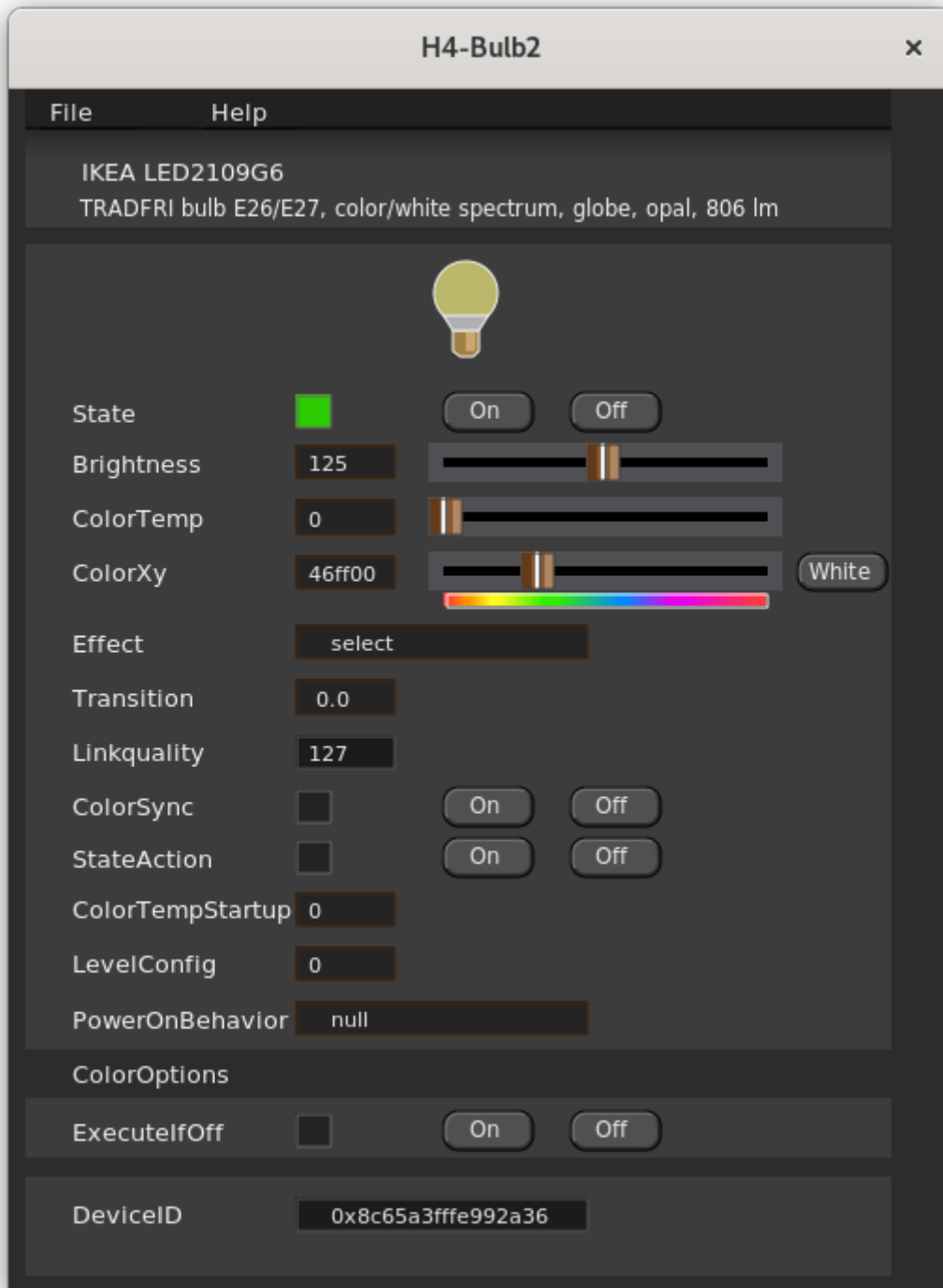

Fig Object graph for IKEA bulb

## ***Script functions***

### **Common script functions**

#### ***file\_search()***

Search for files.

A pattern with wildcard can be specified to search for several files. The search sequence is divided in the passes init, next and end. At the first call pass init (1) is specified. At search of more files with the same patter the pass next (1) is specified. The search is closed with the pass end (2).

Returns odd status if a file is found, else even status.

Example

```
string pattern = "*.txt";
string found_file;
int sts;

sts = file_search(pattern, found_file, 1);
while (sts & 1)
    printf("Processing %s\n", found_file);
    ...
    sts = file_search(pattern, found_file, 0);
endwhile
file_search(pattern, found_file, 2);
```

#### ***terminate()***

Terminate the process.

### **Ge script functions**

#### ***PushSelected()***

Push the selected objects.

#### ***PopSelected()***

Pop the selected objects.

### ***Wireshark QCom and RedCom dissectors***

The Wireshark QCom and RedCom dissectors are updated. The source code is found in src/tools/wireshark. Read in src/tools/wireshark/README how to build the dissectors with Wireshark.

## **Upgrade procedure**

The upgrading has to be done from any V6.0. If the project has a lower version, the upgrade has to



be performed stepwise following the schema

V2.1 -> V2.7b -> V3.3 -> V3.4b -> V4.0.0 -> V4.1.3

→ V4.2.0 → V4.5.0 → V4.6.0 → V4.7.0 → V4.8.6 → (V5.0.0) → V5.1.0 → V5.2.0 → V5.3 → V5.4 → V5.5

→ V5.6 → V5.7 → V5.8 → V5.9 → V6.0 → V6.1

Enter the administrator and change the version of the project to V6.1.0. Save and close the administrator.

Do a sdf to the project and run upgrade.sh.

If you have any class volumes, enter the class editor and build the volume.

Enter the configurator for each root volume and activate 'Function/Update Classes' and build.